

BL2000-QKB-V2
Group Control

Instruction manual

Ver: V1.0

Contents

CHAPTER 1	ELEVATOR GROUP CONTROL SYSTEM INTRODUCTION	1
1.1	GROUP CONTROL BOARD BL2000-QKB-V2	1
1.2	GROUP CONTROL AND MAIN CONTROL BOARD SYSTEM BLOCK	2
1.3	INTRODUCTION OF WORKING MODE	2
CHAPTER 2	ELEVATOR GROUP CONTROL SYSTEM DESCRIPTION	3
2.1	LCD KEYPAD OPERATION DESCRIPTION	3
2.2	LCD DISPLAY FLOWCHART AND DESCRIPTION	4
2.3	GROUP CONTROL STATUS AND COMMUNICATION	5
2.4	EACH ELEVATOR STATUS AND DESCRIPTION	6
2.5	GROUP CONTROL BOARD INTERNAL LOGIC STATUS	6
2.6	PASSWORD SETTING	6
2.7	SAVE PARAMETER	7
2.8	CHANGE PASSWORD	7
2.9	GENERAL PARAMETER SETTINGS	7
2.9.1	Group able set	7
2.9.2	S.X.N quotient	8
2.9.3	Mode Select	8
2.9.4	Set System Time	8
2.9.5	Set On Duty Time / Off Duty Time	9
2.9.6	Set Non-Stop Floor	9
2.9.7	Set Homing Floor	10
2.10	SETTING REQUIREMENT FOR GROUP CONTROL VERSUS ELEVATOR NUMBERS (A, B, C, ...)	11
2.11	GROUP CONTROL ELEVATOR BOTTOM FLOOR SETTING	11
APPENDIX	ADDITIONAL DESCRIPTION	13

Chapter 1 Elevator Group Control System Introduction

The SJT-WVF5 Group Control System is composed of Group Control Card BL2000-QKB-V2 and every distributed elevator main control board.

It is applying the serial communication network CAN centralize system to communicate with all elevator controller to exchange information. After gathering all the information, the microprocessor unit will begin the logic analyzing and computation on it, following by outputting the relevant commands and responses. It can achieve up to 8 cars group control with maximum 64 floors each elevator.

SJT-WVF5 elevator group control system can achieve the following four kinds of operating mode.

1.1 Group Control Board BL2000-QKB-V2

Unit: mm

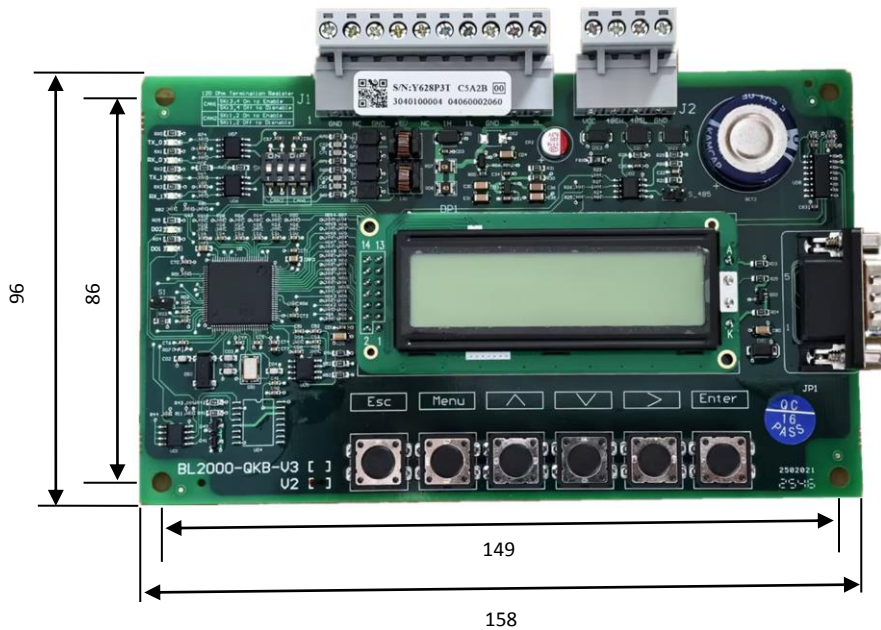

Figure 1.1 BL2000-QKB-V2 physical and dimensional drawing

Note: Confirm whether the product model is V3 or V2 based on the silk screen configuration.

1.2 Group Control and Main Control Board System Block

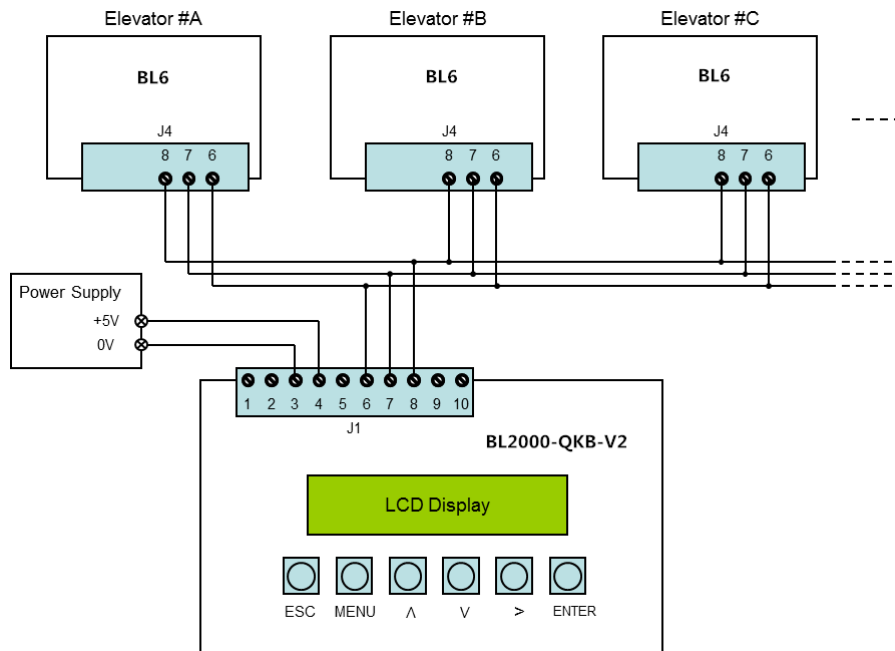

Figure 1.2 Group Control and Main Control Board System Block

1.3 Introduction of Working Mode

On Duty Mode

Elevators are assigned to homing floor to serve up peak traffic during the preset time (refer to SJT-WVF5 user manual for setting the homing floor).

Off Duty Mode

One elevator is assigned to serve up traffic, the rest of the elevators in the group are assigned to serve the down peak traffic.

Balance Mode

Hall calls are being divided into a few regions so as to serve the hall call registrations as soonest as possible.

Standby Mode

During Balance Mode operation, if no car call or hall call is made for 3 minutes, the elevators will be assigned to standby at the first floor of each region, this is to increase the efficiency of attending hall call registration.

Note that if the elevator is faulty, or in Attendant mode, Inspection mode, Parking mode, Fireman mode, Independent mode, then it will be removed from the Group control bank.

The operation and setting of each elevator in the group control bank shall be referred to SJT-WVF5 elevator control system testing and commissioning manual.

Chapter 2 Elevator Group Control System Description

2.1 LCD Keypad Operation Description

LCD Keypad has six keys.

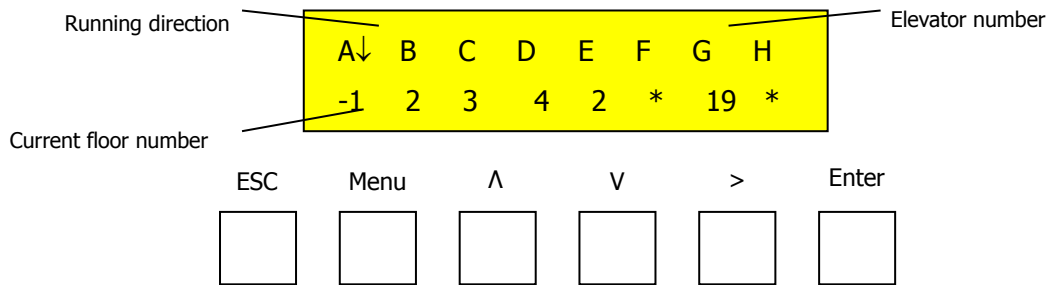

Figure 2.1 The arrangement and definition of LCD keypad

Chart 2.1 The functions of the keys

Key	Description
Menu	Unconditionally return to main menu.
Enter	To enter to the next level of menu, to confirm the modified value or the car call registration.
Esc	To escape to the upper level of menu or to cancel the amendment.
>	Right scrolling cursor or to viewing communication status and grouping status in main menu.
Λ	To scroll up one screen, to increase parameter value by one or to select YES (ON).
V	To scroll down one screen, to decrease parameter value by one or to select NO (OFF).

Group control board (BL2000-QKB-V2) uses the LCD display and keypad operation to set the group control system operating modes, hall call up and down, car call availabilities, system date and time, On duty and Off duty times, and to view each elevator running status.

2.2 LCD Display Flowchart and Description

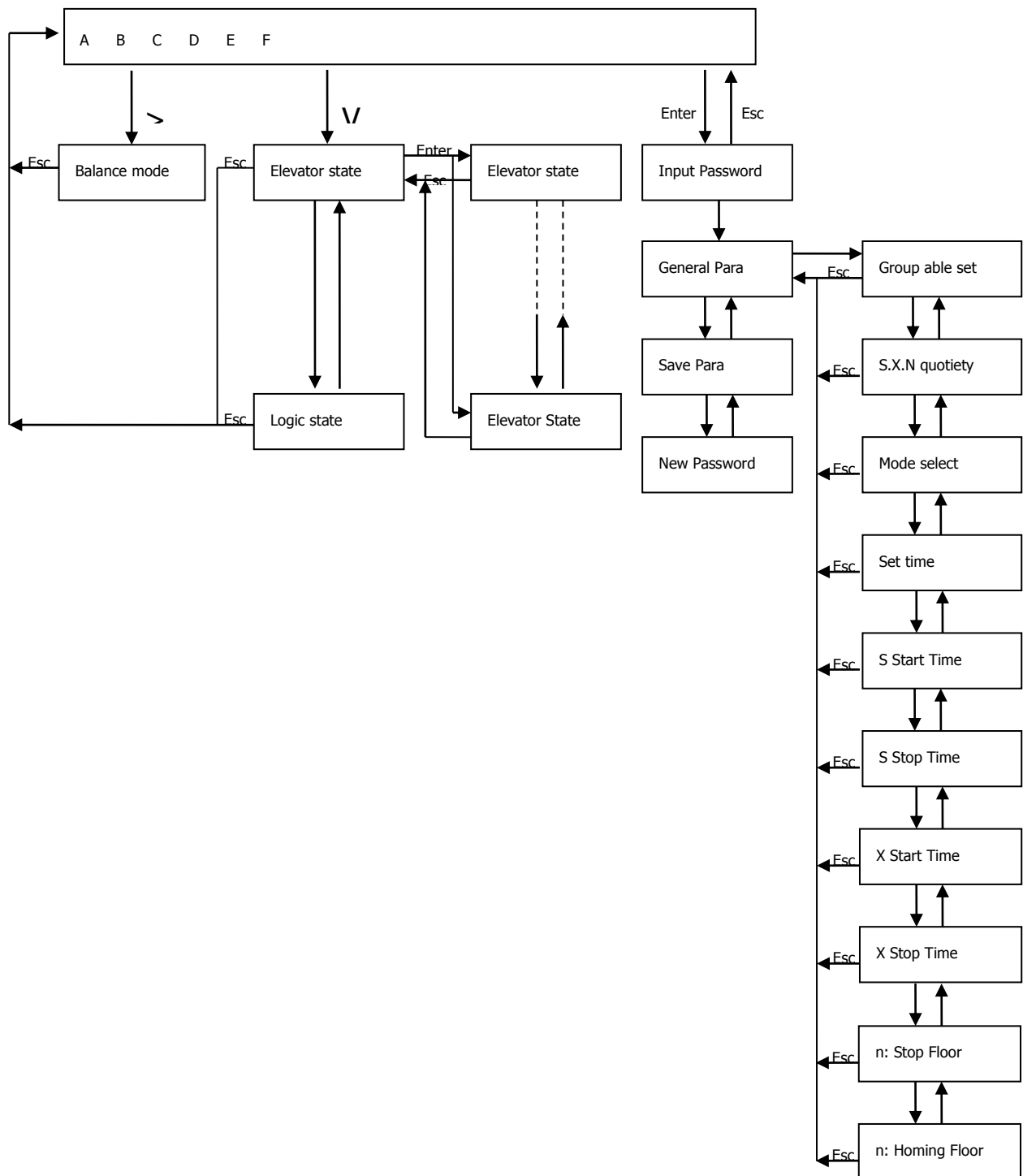

Figure 2.2 LCD Display Flowchart

LCD Display Main Menu Description:

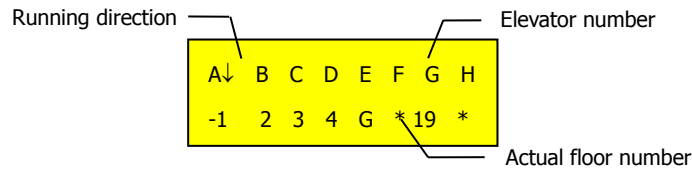

Figure 2.3 LCD Display Main Menu

A, B, C, D, E, F, G and H are representing the eight elevator numbers; the arrow beside it is indicating the elevator running direction; the number or alphabet below the elevator number is showing the current actual floor number; if a symbol “*” is under the elevator number, it means there is communication abnormal or “Group able set” is set to “NO” (or it may be set to Mode:0 in that elevator main control board Group control function).

2.3 Group Control Status and Communication

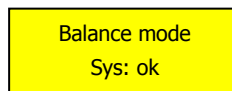

Figure 2.4 Group Control Status

Balance mode:	Hall calls are being divided into groups so as to serve the hall call registration as soonest as possible.
On duty mode:	Elevators are assigned to homing floor to serve up peak traffic during the preset time.
Off duty mode:	One elevator is assigned to serve up traffic, the rest of the elevator in the group are assigned to serve down traffic.
Sys: ok:	Group control communication is normal.
Sys: ET:	Group control communication is abnormal.

2.4 Each Elevator Status and Description

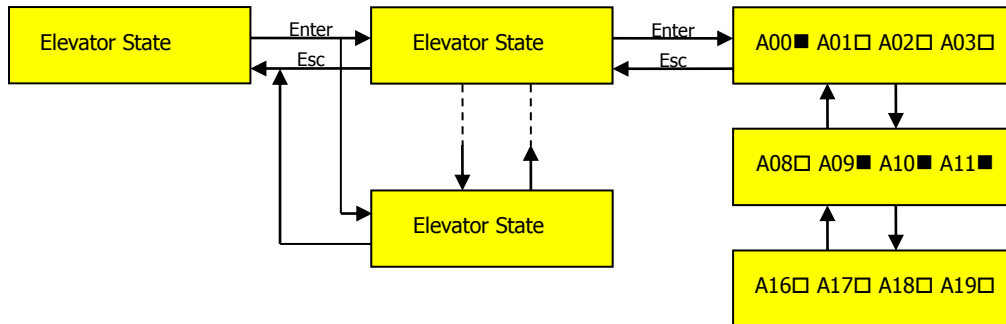

Figure 2.5 Each Elevator Status

Note: “X” is representing the elevator number from “A” to “H”.

Chart 2.2 The functions of the keys

Item	Description	Item	Description	Item	Description
X00	Parking	X08	Over Load	X16	Load Weighting Fault
X01	Total Control	X09	Light Load	X17	FJ-CZB Fault
X02	Inspection	X10	Full Load	X18	
X03	Door Interlock Contact	X11	Attendant Y/N	X19	Emergency Stop
X04	Speed Change	X12	Fault	X20	Door Zone
X05	Running	X13	Fireman	X21	Door Fault
X06	Down Direction	X14	VIP	X22	Door Open Fault
X07	Up Direction	X15	Buzzer	X23	Door Close Fault

2.5 Group Control Board Internal Logic Status

For internal used only.

2.6 Password Setting

Password (User Level or Factory Level) must be correctly entered in order to enter into Parameter Setting menu.

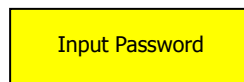

Figure 2.6 Input Password

In the Input Password menu, use “^” key to increase the number, or “v” key to decrease the number, use “>” key to scroll the desired password position. Press “Enter” key to enter the correct password, hence to enter into the General Parameter setting menu. Or else it will display:

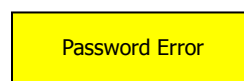

Figure 2.7 Password Error

2.7 Save Parameter

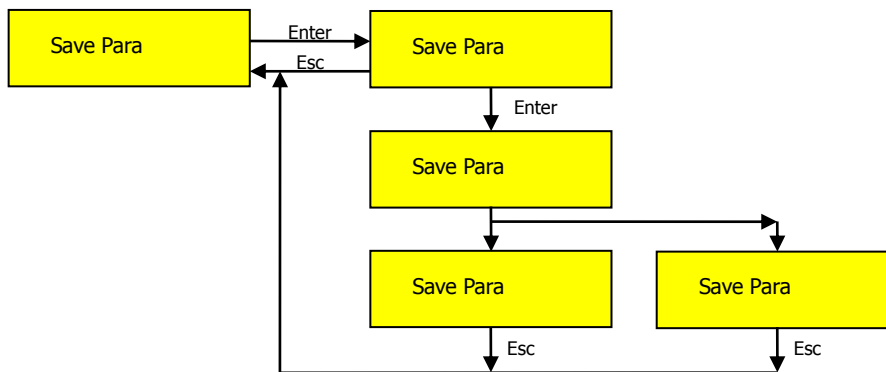

Figure 2.8 Save Parameter Status

After entering into “Save Para” menu, press “Enter” to select “Yes”, the system will automatically save the amended parameter. “Success” will be displayed if the saving is succeeded, or else “Failure” is shown. If the saving is failed, please contact factory for further assistance.

Note: Any changes in parameter setting will be effective immediately, however, if “Save Para” is not performed, when system power is cut off, the changed parameter setting will be reverted to before value.

2.8 Change Password

It is for changing and setting new User Password.

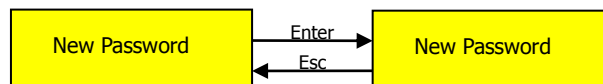

Figure 2.9 Change Password Status

2.9 General Parameter Settings

2.9.1 Group able set

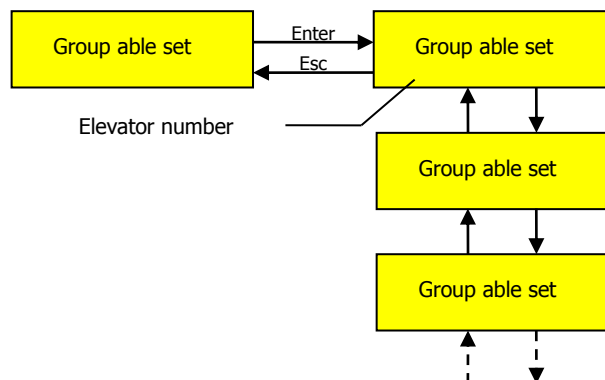

Figure 2.10 Group able Status

Set “Yes” for the each elevator in the group bank.

2.9.2 S.X.N quotient

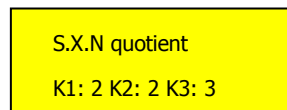

Figure 2.11 S.X.N quotient Status

The value K1, K2 and K3 are for internal use, do not change the factory setting. (Note: “S” = Up Hall Call, “X” = Down Hall Call and “N” = Car Call)

2.9.3 Mode Select

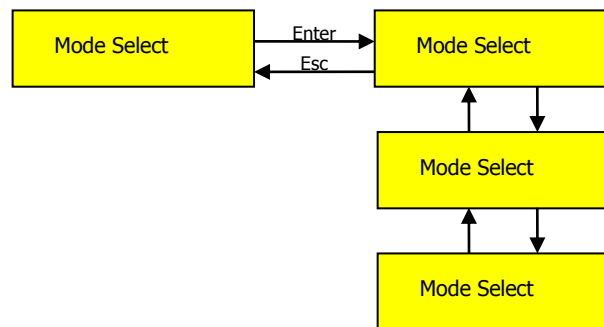

Figure 2.12 Mode Select Status

- Mode 0 : spare, not used.
- Mode 1 : On Duty Mode; if “Yes”, during the preset “On Duty” time, the Group system will enter the On Duty Mode.
- Mode 2 : Off Duty Mode; if “Yes”, during the preset “Off Duty” time, the Group system will enter the Off Duty Mode.

When “On Duty Mode” is set to “Yes”, during the prefix start working hours, the group control system will enter On Duty mode; when “Off Duty Mode” is set to “Yes”, during the prefix finish working hours, the group control system will enter Off Duty mode; if “On Duty Mode” is set to “No”, the group control system will never enter On Duty mode; similarly, if “Off Duty Mode” is set to “No”, the group control system will never enter Off Duty mode. If both “On Duty Mode” and “Off Duty Mode” are set to “No”, then the group control system will be operated in averaging running mode.

2.9.4 Set System Time

To display and to set the system date & time; YY-MM-DD HH:MM

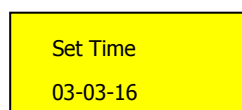

Figure 2.13 Set System Time Status

2.9.5 Set On Duty Time / Off Duty Time

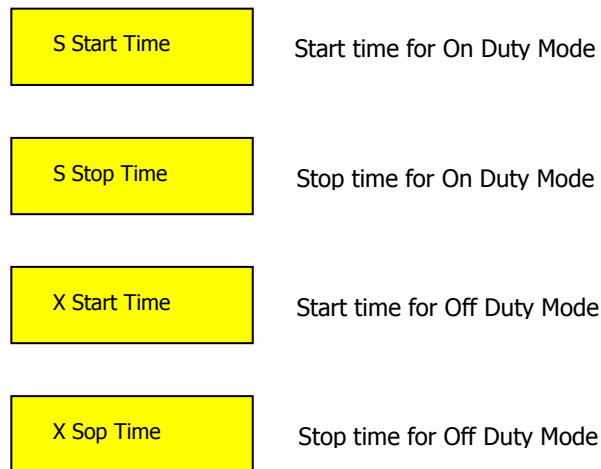

Figure 2.14 Set Duty Time Status

When “On Duty Mode” is set to “Yes”, group control system will enter On Duty mode between the start and stop On Duty mode times.

When “Off Duty Mode” is set to “Yes”, group control system will enter Off Duty mode between the start and stop Off Duty mode times.

When “On Duty Mode” and “Off Duty Mode” have been set to “Yes”, if the system time is greater than “S Start Time” and smaller than “S Stop Time”, the Group system will enter the “On Duty Mode”; If the system time is greater than “X Start Time” and smaller than “X Stop Time”, the Group system will enter the “Off Duty mode”.

Note: “S” stands for Up Peak On Duty; “X” is stands for Down Peak Off Duty.

2.9.6 Set Non-Stop Floor

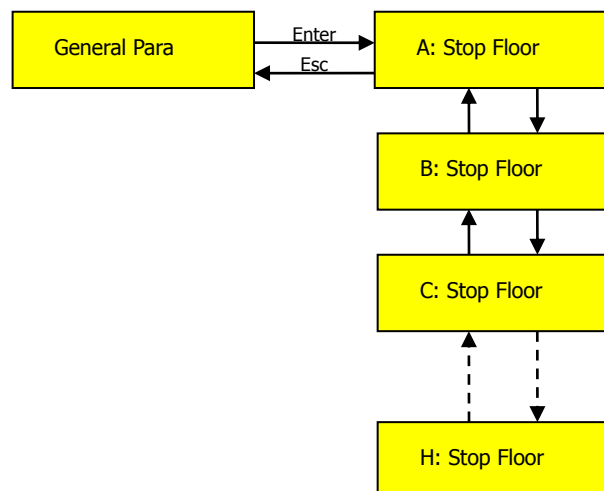

Figure 2.15 Set Non-Stop Floor Status (1)

If there is any non-stop floors setting required in the Group control system, the non-stop floor setting in every main control board must be similar to the setting in Group control system.

Please be noted that the Main control board is using actual floor number(s) in the non-stop floor setup, whereas, the Group control system is using relative floor number(s) in the non-stop floor setup. If the setup of non-stop floor is wrong (non-stop floor set in Main control board is not corresponding to the non-stop floor set in Group control system), the system will have conflict in responding to registered calls (like travelling directions and run contactor (KDY) ON-OFF repeatedly).

When setting up the non-stop floor in Group control system, all elevators (A to H) must be set to the same configuration. If there is any inconsistent setting on every elevator, (for example, Floor "02" is set to "ON" in Elevator-A, but Floor "02" is set to "OFF" in Elevator-B), then the Group control will perform call distribution wrongly for passengers who want to travel to Floor "02".

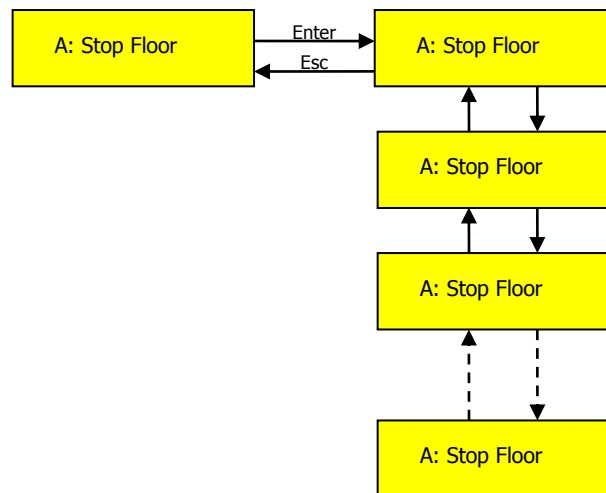

Figure 2.16 Set Non-Stop Floor Status (2)

2.9.7 Set Homing Floor

This function is available for software version 706_12 and higher versions.

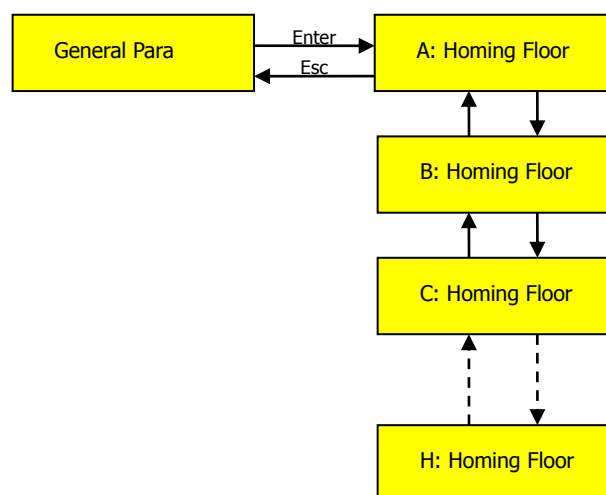

Figure 2.17 Set Homing Floor (1)

When the elevator group is idle (no car and hall calls for 5 minutes), if the Homing Floor is set to "0" for every elevator in the group control system, the group control system will automatically distribute the elevators to average region based on number of floor; for example, if there is a 20 floors building having 3-car Group control system, Elevator-A will be distributed to Floor 01 for waiting call, Elevator-B will be distributed to Floor 06 for waiting call and Elevator-C will be distributed to Floor 12 for waiting call.

When the setting of Homing Floor is not "0", the elevator will be distributed to the designated floor when it is idle for 5 minutes.

Remarks:

- (1) If Group control Homing Floor is not utilized (all set to "0"), the Group control system will distribute the elevators to average region for waiting calls;
- (2) During Group controlling, the Homing Floor setup of every Main control board will be null and void;
- (3) The Group control system is using absolute relative floor number(s) in the Homing Floor setup. ("1" = lowest floor, so on and so forth)

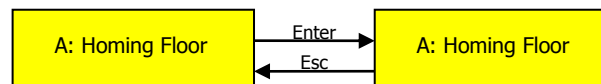

Figure 2.18 Set Homing Floor (2)

2.10 Setting requirement for Group Control versus elevator numbers (A, B, C, ...)

- (1) On every elevator controller of the group control, the setting for fireman "Fire Floor" and "Homing Floor" must be the same;
- (2) In Group control system (3-car group and above), if the bottom floors are not same (some elevators are having basement floors), the most lowest floor elevator should be set to Elevator A, the second most should be set to Elevator B and so on and so forth; If the bottom floors are same whereas the top floors are not same, hence the highest floor elevator should be set to Elevator A; If none of the above mentioned, elevator numbers can be randomly set.

2.11 Group Control Elevator Bottom Floor Setting

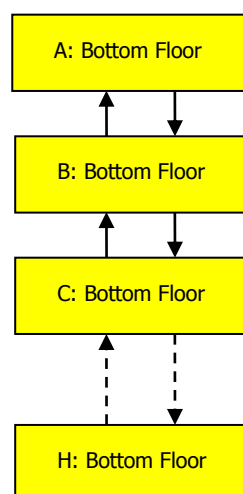

Figure 2.19 Group Control Elevator Bottom Floor Setting

The purpose of configuring the Bottom Floor of each elevator is to prevent staggered floor, if elevators A, B, C and D are having the same Bottom Floor, then all settings shall be set to **1**. If there are elevators in a group having different basement floors, then the Bottom Floor shall be correctly set, for example, elevator A floor numbers are B2, B1, G, 1, 2, 3, while elevator B floor numbers are G, 1, 2, 3, then Elevator A has the lowest basement floor, the entire group destination control total floor is 6 floors, therefore:

- ❖ Elevator A’s lowest floor B2 is considered as **1** of the group base floor number, and its Bottom Floor shall be set to **1**;
- ❖ Elevator B’s lowest floor G is considered as **3** of the group base floor number, and its Bottom Floor shall be set to **3**, and so on the other elevators’ Bottom Floor settings.

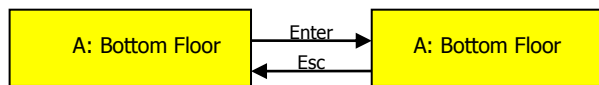

Figure 2.20 Bottom Floor Setting

The following is an example of Bottom Floor setting for Group Destination Control:

There are two elevators, A and B; where, Elevator A has two basement floors, and Elevator B has no basement floor.

Table 2.3 Example of Bottom Floor setting for Group Destination Control

Absolute Floors of Destination Control	1	2	3	4	5	6	7	8	...
Absolute Floors of Elevator A Controller	1	2	3	4	5	6	7 Non-stop	8	...
Floor Numbering of Elevator A	B2	B1	G	1	2	3	4 Non-stop	5	...
Absolute Floors of Elevator B	X	X	1	2	3	4 Non-stop	5	6	...
Floor Numbering of Elevator B	X	X	G	1	2	3 Non-stop	4	5	...
Note: <ul style="list-style-type: none"> • “Non-stop” stands for non-stopping floor • “X” stands for unavailable floor 									

- ❖ The absolute floor numbers are used as the basic reference for destination control system.
- ❖ The Bottom Floor settings for Elevator A shall be **1**, and Elevator B shall be **3**;
- ❖ The Homing Floor setting for Elevator A shall be **3**, and Elevator B shall be **3** in case the Homing Floor is required at G floor. The Homing Floor for each elevator can be set differently.
- ❖ The Non-Stop Floor setting for Elevator A shall be **7**, and Elevator B shall be **6**.
- ❖ The Floor Indication setting for group control shall be: **1: B2, 2: B1, 3: G, 4: 1, 5: 2, ...**

Appendix Additional Description

In case of Group control, the terminal resistor of main control board for group control communication must be removed except the Group control card BL2000-QKB-V2 and the furthest Main control board. See below diagrams:-

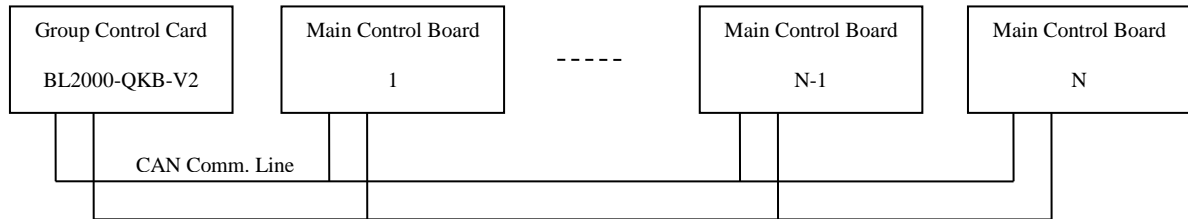

Remove the terminal resistors R287 & R252 (which resistor has marking 620, i.e. 62 ohm) near to J4 of Main control boards from board 1 to board N-1.

Remain the terminal resistors on Group control card and the furthest Main control board N.